



## TT96E

Conveyor pizza oven

### COMPOSITION WITH 1 BAKING DECK



#### OPTIONS AND ACCESSORIES (WITH SURCHARGE)

- Support with castors, height 600mm complete with pocket for screens
- Online connection REMOTE-MASTER® TECHNOLOGY

#### MORETTI FORNI S.P.A.

www.morettiforni.com  
info@morettiforni.com

Via A.Meucci, 4 - 61037 Mondolfo (PU) ITALIA  
Tel. +39.0721.96161 - Fax +39.0721.9616299

#### EXTERNAL CONSTRUCTION

- Structure in folded stainless steel sheets
- Stainless steel door hinged on left hand side with logo BlackBar Design
- Stainless steel access flap hinged at bottom
- Tempered glass window
- Low-cluttered handle
- Extractable stainless steel conveyor belt, with continuous tensioning
- Electronic control panel on front left side

#### INTERNAL CONSTRUCTION

- Baking chamber in stainless steel sheets
- Top and bottom blowers in welded stainless steel sheets, extractable for cleaning
- Rock wool heat insulation, thermal joints and air space COOL AROUND® TECHNOLOGY

#### FUNCTIONING

- Heated by armoured heating elements powered independently in adaptive mode
- Control of power PID (Proportional Supplementary Derivative) can allow the automatic regulation of energy necessary on the basis of the quantity of the batch product and the position inside the baking chamber ADAPTIVE-POWER® TECHNOLOGY
- Independent adjustment and control of ceiling and floor, both on the input side and the output one of the baked product, with continuous temperature detection using 4 high sensitive thermocouples DUAL-TEMP® TECHNOLOGY
- Air blowing system using 2 stainless steel fans independently motorized
- Conveyor belt with speed adjustable from 45" to 20 minutes using Brushless engine at the option of belt standstill
- Programmable electronic function management ECO-SMARTBAKING®
- Maximum temperature reached 320°C (608°F)
- Independent system for additional forced air cooling of the components with low noise

#### STANDARD EQUIPMENT

- Color multilanguage display TFT 5"
- 100 customisable programs
- ECO-STAND BY® TECHNOLOGY Saving device with the possibility to stop the belt for break
- Discontinuous baking cycle STEP
- Double pass baking cycle RETURN
- Start-Stop function to move tape to the set point is reached
- LOCK function
- Weekly Timer with the possibility to program two lightings and two power off every day
- Customized Hotkey with recurring control
- Auto test with display of error message
- USB slot for data reading / programs DATA-FEED® SYSTEM
- Double independent safety devices of minimum blowing pressure and maximum temperature device
- Stainless steel product stand



## TT96E 1 DECK

(assembled with support height 600mm complete with pocket for screens)

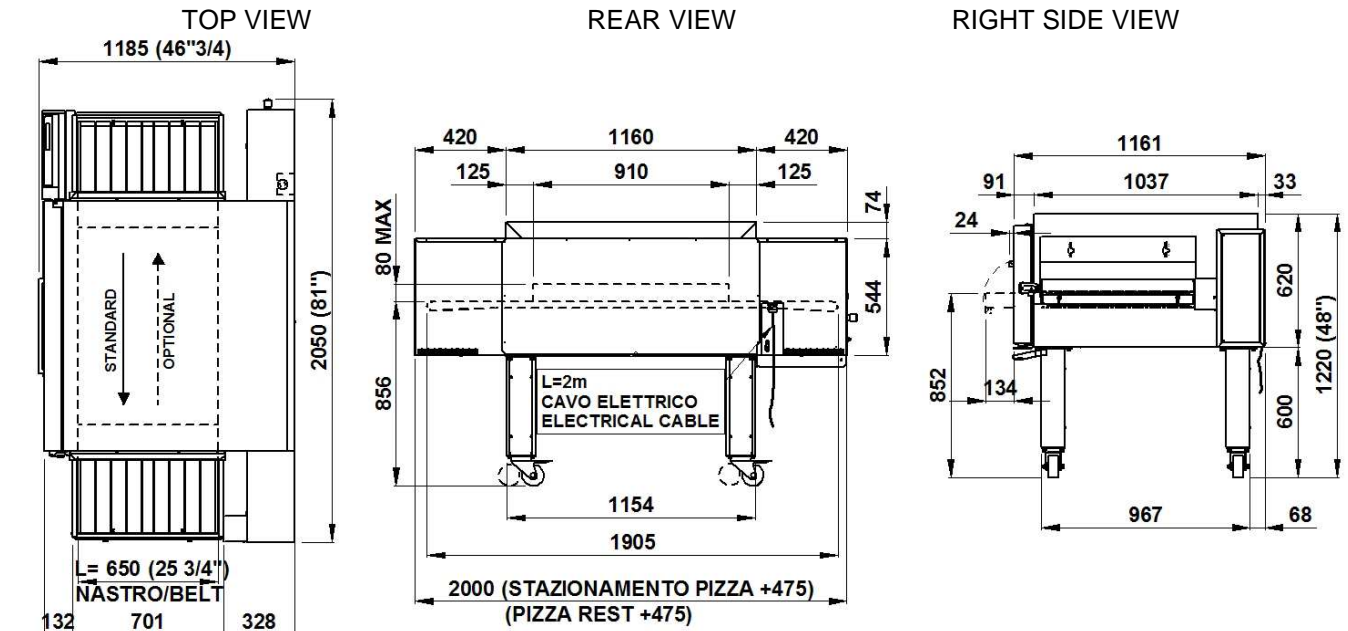

**Note:** The dimensions indicated in the views are in millimeters.

### SPECIFICATIONS

The appliance comprises one baking element and an optional support. Baking takes place by passing the product between two adjustable flows of hot air, which allow perfect distribution of heat throughout the chamber, making this oven particularly suitable to bake pizza and other alimentary products. The regulation of power is automatic in basis of the load, the ceiling and floor resistors, both on the input side and the output one of the baked product, are controlled independently, and the belt speed is reverse controlled and adjustable. Stainless steel access flap hinged at bottom with tempered glass window. Efficiently insulated and isolated, the outer surfaces are further cooled by a at very low noise flow of air. The support comprises steel legs on swivel castors. The maximum temperature in the baking chamber is 320°C (608°F).

All the data give below refers to the configuration with 1 baking deck

DIMENSIONS	SHIPPING INFORMATION	FEEDING AND POWER	
External height	1220mm	Dimensions of packed oven	
External depth	1185mm	Height	790mm
External width	2050mm	Depth	1325mm
Weight (excl.supp)	297kg	Width	2152mm
Tot. baking surface	0,59m <sup>2</sup>	Weight	(297+25kg)
		Frequency	50/60Hz
TOTAL BAKING CAPACITY	PACKAGED DIMENSIONS	SUPPORT	
*N° Pizzas/hour		Max power	17,8kW
Pizzas diameter 330mm	N°100	*Medium cons/hour	7,8kWh
Pizzas diameter 450mm	N°38	Connecting cable	
	Height	type H07RN-F	
	Depth	5x6mm <sup>2</sup> (V400 3N)	
	Width	4x10mm <sup>2</sup> (V230 3)	
	Weight		

\*This value is subject to variation according to the way in which the equipment is used

- **NOTE:** MORETTI FORNI S.P.A. reserves the right to modify the characteristics of the products illustrated in this publication without prior notice